

AP1464

Apollo

Oliveri®

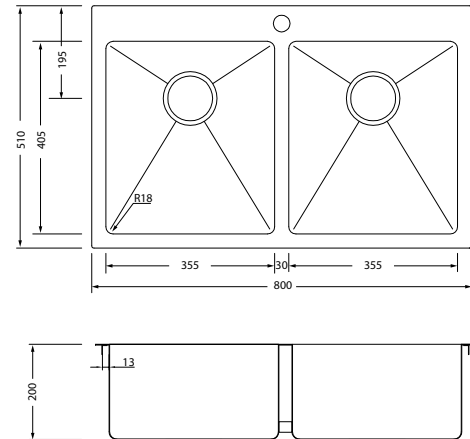

INCLUDED ACCESSORIES



RECOMMENDED TAPWARE



OPTIONAL ACCESSORIES



SPECIFICATIONS

Description

Double bowl sink

Sink Size

800W x 510H

Main Bowl

355W x 405H x 200D / 29L

Main Bowl

355W x 405H x 200D / 29L

Construction

Fabricated with 18mm radius corners, Softtone® and soundproofing.

Material

304 grade, 18/10 brushed stainless steel (1.2mm thick)

Installation

Inset, undermount or flushmount

Fixings

Topmount clips supplied

Cut Out Template

oliverisinks.com

Min Cabinet Size

900mm

Tap holes

Available 1 tap hole only (suitable for additional tap holes)

Waste fittings

2 x 90mm basket wastes included

Overflow

Not available

Carton Size

855 x 570 x 270mm

Weight

15.0kg

Warranty

Lifetime manufacturer's warranty (refer to oliverisinks.com)

For more information call **1300 13 7465** or visit **www.oliverisinks.com**

